

▷ BR-1810A parameter

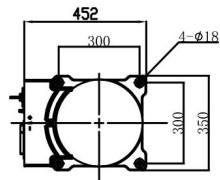

VIEW A

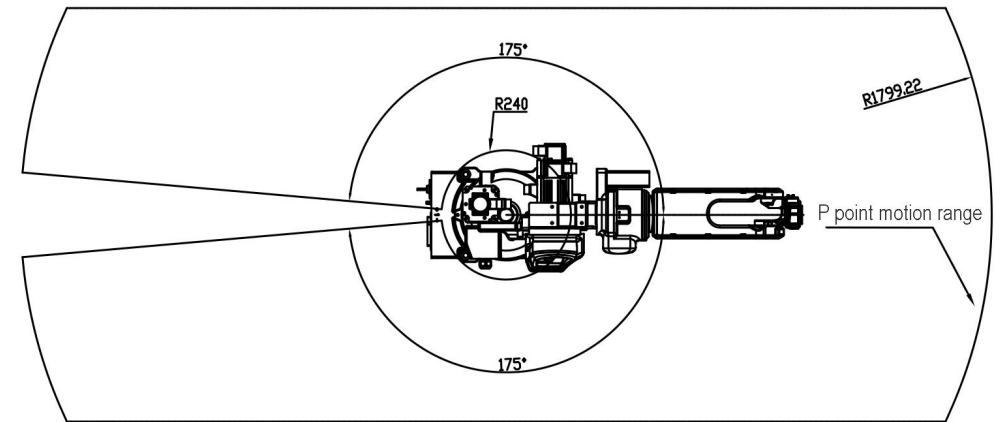
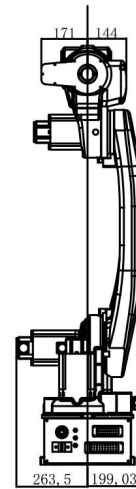
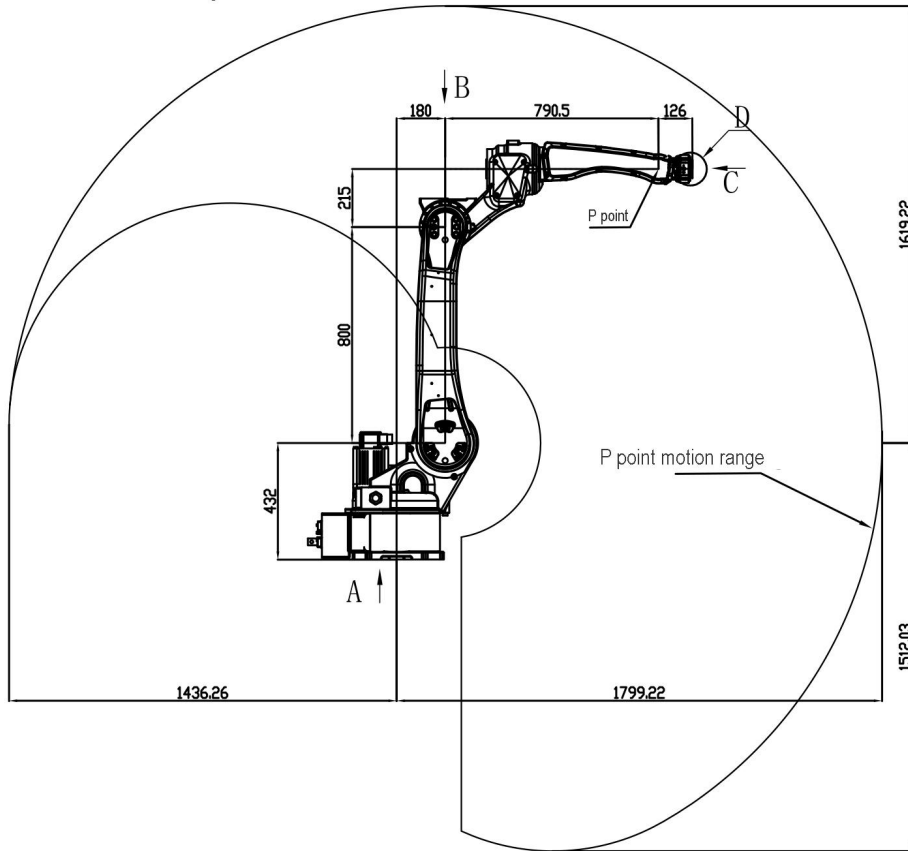
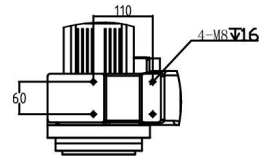

VIEW B

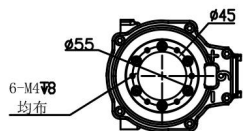

VIEW C



VIEW D

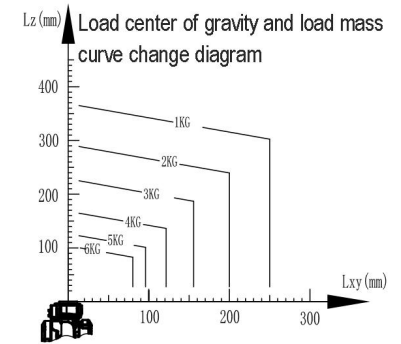

Model	BR-1510B	Motion Range	J1	±170°	Motion Speed	J1	259.3° /s
Axis	6		J2	+130° ~ -65°		J2	160° /s
Reach(about)	1500 mm		J3	±75°		J3	296.3° /s
Max Payload	10KG		J4	±150°		J4	294.1° /s
Repeatability	±0.08mm		J5	+105° ~ -125°		J5	296.3° /s
Power Capacity	2KVA		J6	±360°		J6	294.1° /s
Protection Class	IP65	Installation Method	Ground				
Robot Weight	172KG	Use Environment	0-45°C, 20-80%RH(No condensation)				
Function	handling welding	Input Voltage	Single-phase 220V ± 10% 50/60Hz				